



Engineering  
with nature

## Multigo submersible Pumps



- A solid WISY concept: pressure instead of suction!
- Multigo pressure pumps bring the pressure from the storage tank directly into the house
- That is why no noises can be heard in the house
- Various suction filters can be fitted
- Supplied with a 1" hose nozzle or 1¼" suction connection (female)

### Pressure instead of suction

WISY was always trend-setting with new ideas for rainwater utilization. WISY is continuing this trend with the further developed Multigo Pressure Pump series:

- For the first time it is possible to connect floating or fixed suction fine filters to a submersible pump, according to requirements. This protects the pump from sucking sediment and thus increases the safety of every rainwater installation.
- The water is pressed out of the cistern directly into the pipe-work to the point of use. This pressure principle avoids the otherwise usual uncertainties of suction pumps operating inside a house.
- The pumps of the Multigo series have several stages of output and will meet many demands: the very good output often makes the use of expensive double pump installations unnecessary.

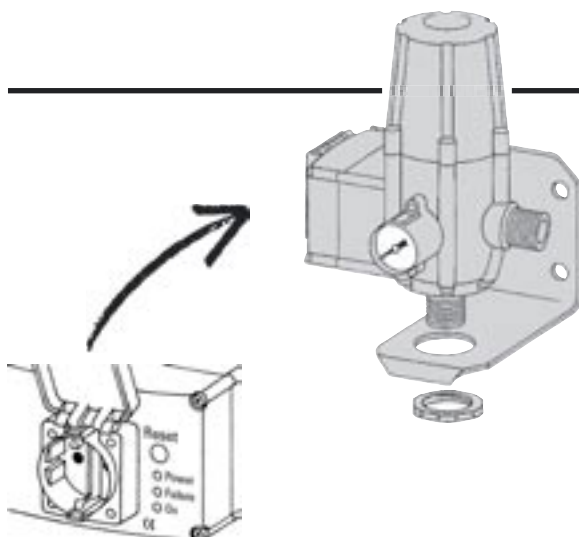

### The Automatic switch SA 06

- The SA 06 controls the pumping operations for water extraction, on and off completely automatically and noiselessly.
- High operating safety through electronic controls
- Integrated backflow prevention maintains the pipe pressure in the house supply.
- The SA 06 protects the pump from running dry and from water hammer.
- Each stage of operation is clearly shown by illuminated diodes.

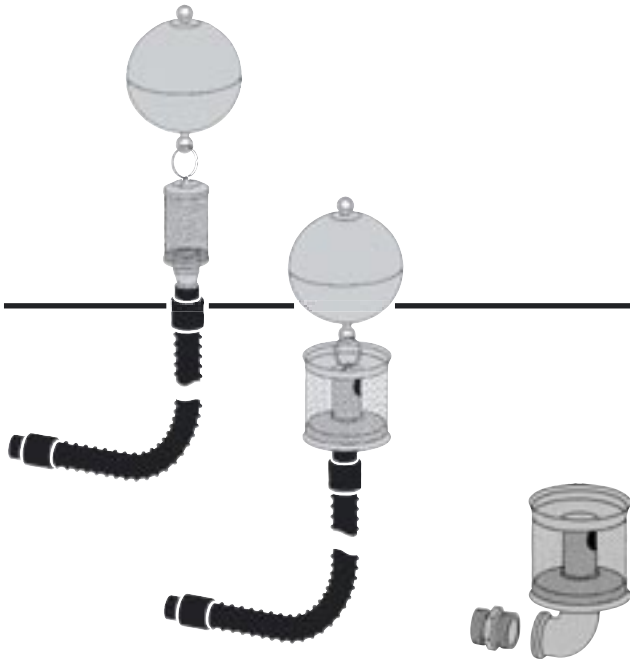

### Pump connections

Multigo and also Provedo submersible pumps can be fitted with floating or fixed pump connections.

### Accessories



- **Bracket**  
Stainless-steel bracket for horizontal installation of submersible pumps in storage tanks (e.g. ribbed plastic cisterns).
- **Baseplate (220 x 220 mm)**  
Stainless-steel baseplate for submersible pumps (Multigo/Provedo) for maximum security in cisterns.
- **Wall mounting for automatic switch SA06**  
The stable wall mounting provides a secure placing in various positions and easy and fast installation on the wall.

### Operating / Output data

Model	P1 Power KW	Average current A	Max. pumping high in m
Multigo 40/06	0,80	3,4	39,0
Multigo 40/08	1,00	4,3	47,0
Multigo 80/12	1,33	6,4	49,0
Multigo 40/12	1,42	6,8	72,0

<b>Network voltage:</b>	230 V, 50 Hz
<b>Max. current:</b>	10 A
<b>Max operating pressure:</b>	10 bar
<b>Cut-in pressure with automatic switch:</b>	1,5 bar
<b>Type of protection:</b>	IP 54
<b>Connection thread:</b>	1¼" female